

# ZERO FIT HOLDER INSTRUCTION MANUAL PAT.P **NIKKEN** VER.6.0

Thank you for your purchase of NIKKEN Zero Fit Holder. We can recommend our products with our confidence, however, please read this manual for long terms. And, please keep it where the operator can refer to it whenever necessary. For basic instruction and caution of the Milling Chuck or the Slim Chuck, please read the the Milling Chuck or the Slim Chuck instruction manual respectively.

- In case of CZF (Milling Chuck) style, please rotate the Adjust Cam to the free position. Then, tighten the nose ring until face contact.



If the face contact is not completed, the Adjust Cam can not function. (Free run)

If the Adjust Cam is not at the free position before tightening, you can not tighten the nose ring until face contact correctly.

- For the safety reason, the Cam Ring Lock Screws can not be loosen to remove to the outside. Please loose the Cam Ring Lock Screws slightly to rotate the Cam Ring.

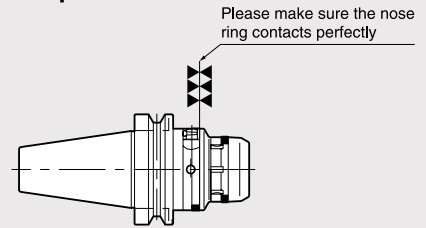

- ① Loosen 2 off Cam Ring Lock Screws and rotate the Adjust Cam to the free position. Set the Dial Gauge at front end of the cutting tool.
- ② Rotate the Zero Fit Holder and stop at the position where the Maximum run-out figure is shown.
- ③ Turn the Cam Ring and locate the Adjust Cam to the "Maximum Run-out" position. Turning the Cam Ring is not affected to the balancing grade, because the Cam Ring itself is well balanced.
- ④ Turn the Adjust Cam by wrench (9ZF) to adjust the run-out to be the middle between the maximum and the minimum. Adjustments made with small movements may take some time to achieve the correct accuracy. It is better to try to adjust the full error in one attempt. With practice this becomes easier.

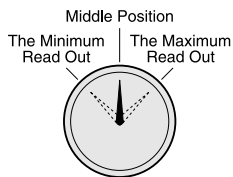
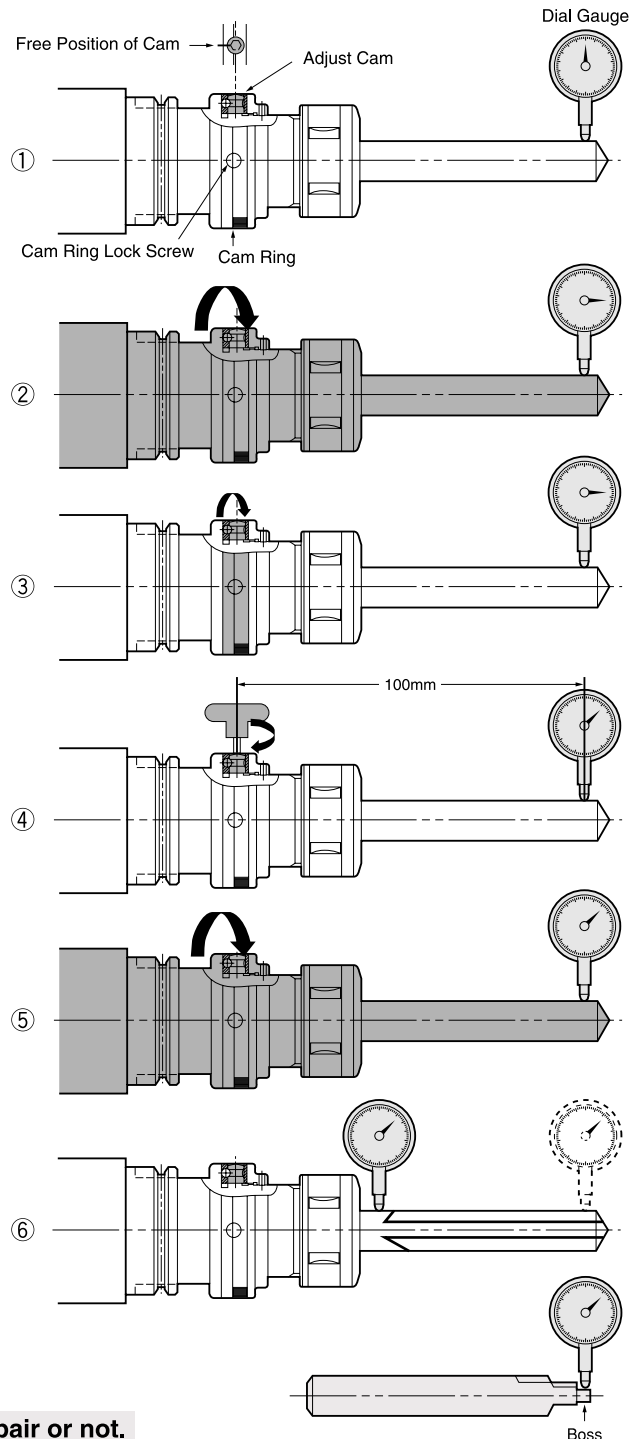

Wrench to adjust 9ZF



Adjustable range of run-out at 100mm from Adjust Cam. (The range will be double at 200mm)	
SZF 6	0.050mm / dia.
SZF10	0.050mm / dia.
SZF16	0.040mm / dia.
SZF25	0.025mm / dia.
CZF20	0.050mm / dia.
CZF25	0.050mm / dia.
CZF32	0.030mm / dia.



Please make sure that the adjustment is made within above range, or the loosening of the Cam might be hard when the adjustment is done over the range.

- ⑤ To make sure please rotate the Zero Fit Holder and check the run-out is adjusted correctly. If adjustment is not correct, loosen the screw to get the Adjust Cam back to the free position and repeat the above procedure from ②. Please ensure that the 2 off Cam Ring Lock Screws are tightened after the above operations.
- ⑥ Please note that there are certain cutters which have the difficulty to check the run-out at their front end. In that case, put the dial gauge on the cylindrical shank portion under the teeth as ⑥ and proceed the above operation ①~⑤. Then, move the dial gauge to the front end and confirm the run-out. If further fine adjustment is required, please do so by using the Adjust Cam only without rotating the Cam ring.

When new special cutter is designed, we will recommend to design to add the boss to check the run-out accuracy at the front end.



– Quotation fee of the repair is always necessary whether repair or not.

This manual is for basic instruction and information for safety use of our product. Please contact with us for the further details. Please note that we could not take a responsibility of the accidental damage on our product which is modified the specifications by the customer without our approval.

**NIKKEN** NIKKEN KOSAKUSHO WORKS, LTD.

Head office : 5-1, 1-chome, Minamishinden, Daito, Osaka, Japan

Tel : 072-869-5820 Fax : 072-869-6220

http://www.nikken-world.com  
e-mail: export@nikken-kosakusho.co.jp